

Dept. Sun Factory	Technical reference A036	Created by Marco Bernardo 10/06/2024	Approved by
		Document type Construction & Assembly	Document status Production
		Title Star Dome Elements	DWG No. A036-STA-20244181
Rev. A.0	Date of issue 17/06/2024	Sheet 1/8	

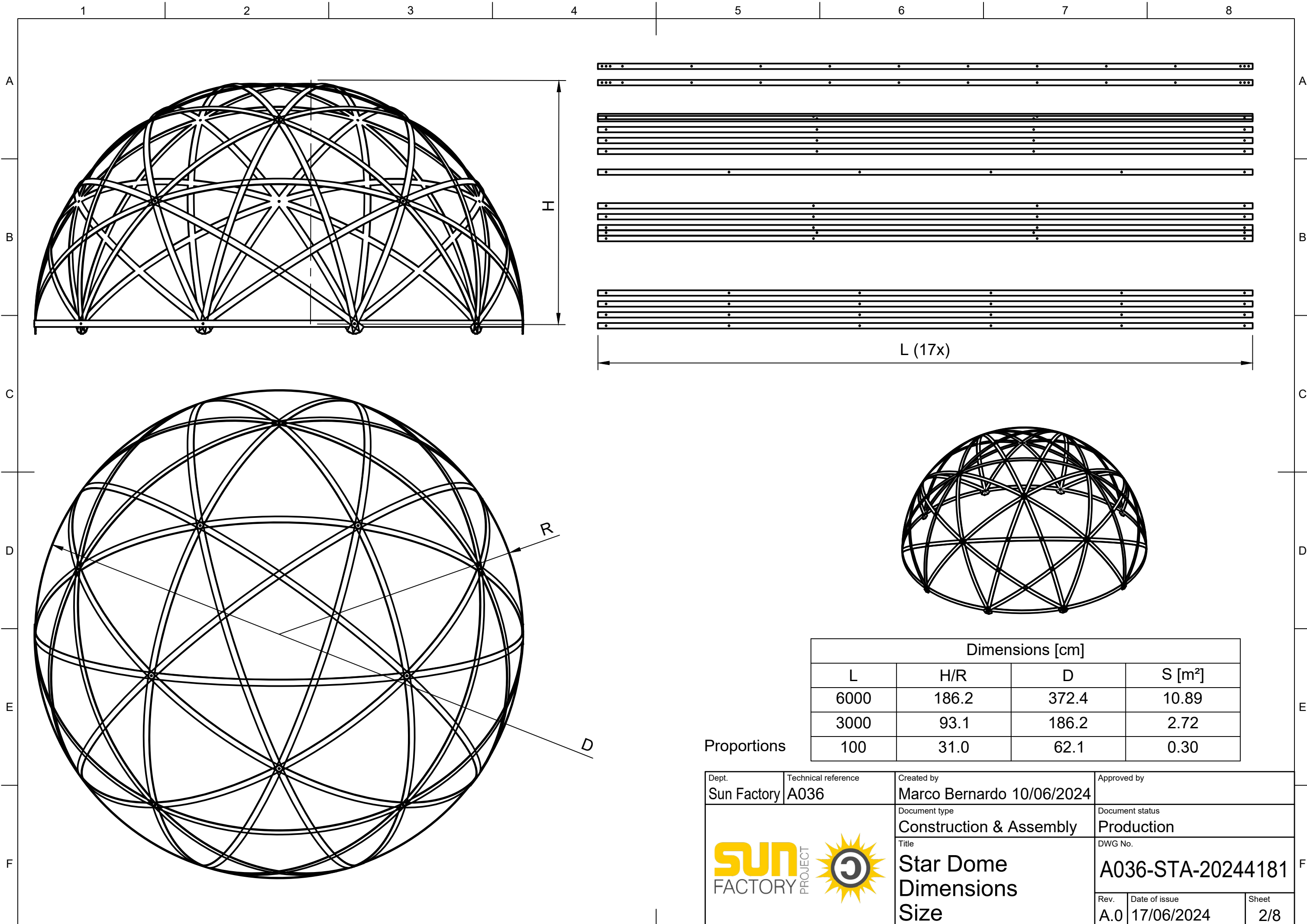

Dimensions [cm]			
L	H/R	D	S [m ²]
6000	186.2	372.4	10.89
3000	93.1	186.2	2.72
100	31.0	62.1	0.30

Proportions

Dept. Sun Factory	Technical reference A036	Created by Marco Bernardo 10/06/2024	Approved by
		Document type Construction & Assembly	Document status Production
		Title Star Dome Dimensions Size	DWG No. A036-STA-20244181
Rev. A.0	Date of issue 17/06/2024	Sheet 2/8	

Parts List	
Description	Qty
Profil A	2
Profil B	5
Profil C	5
Profil D	5

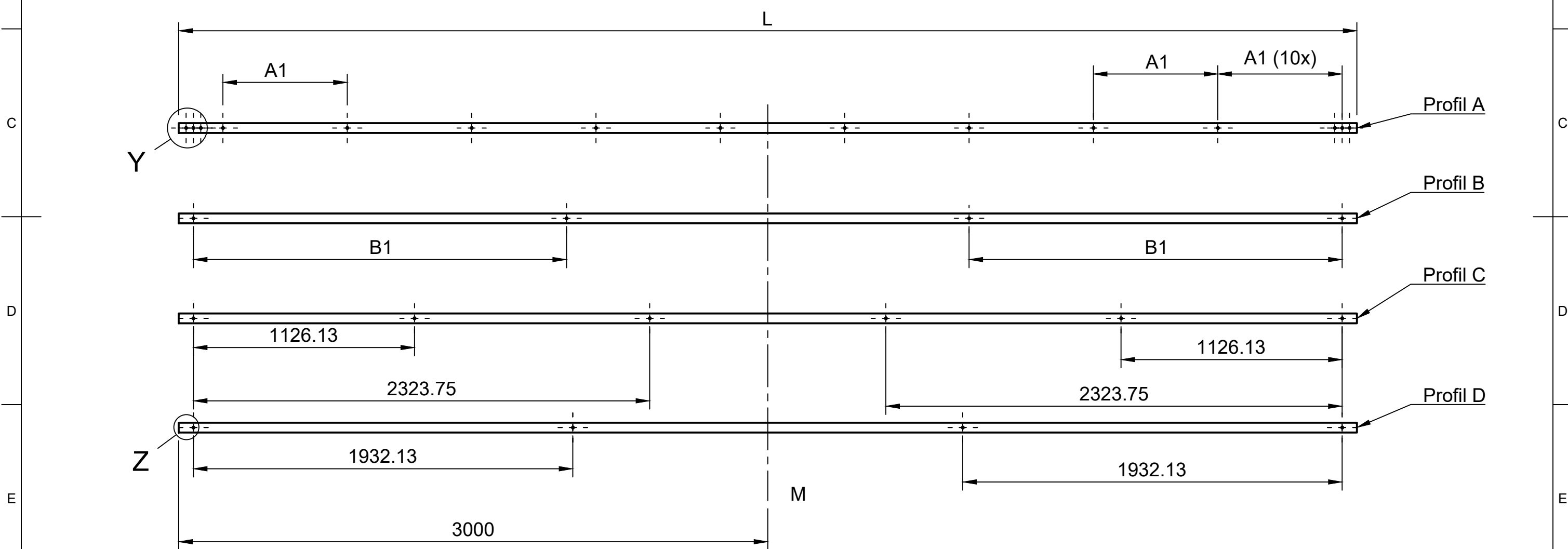
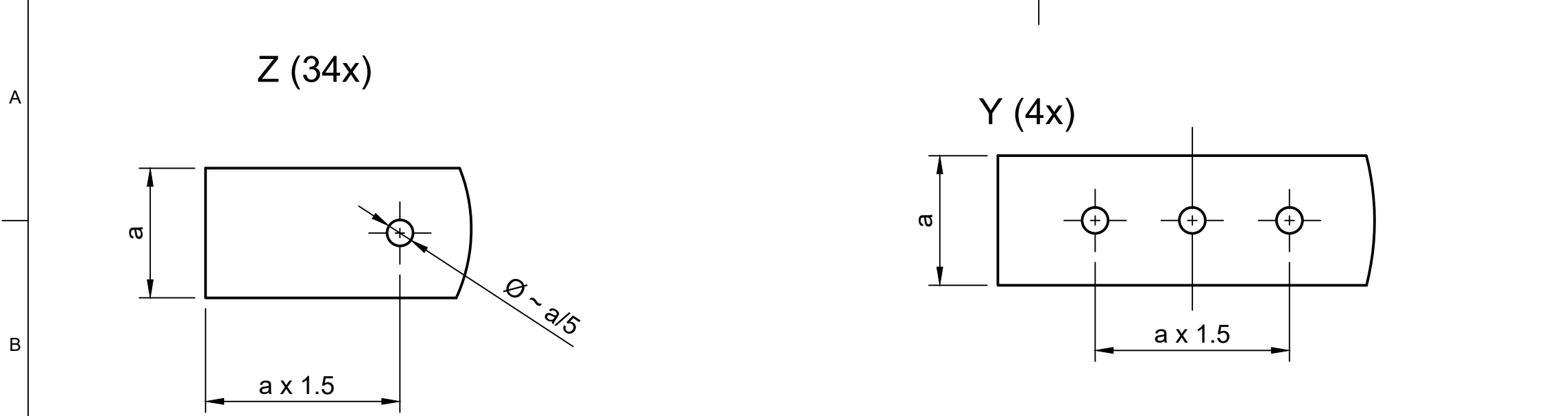

Dimensions [cm]							
L	A1	B1	C1	C2	D1	a (min)	M
600	63.3	190.0	112.6	232.4	193.2	5	300
300	31.7	95.0	56.3	116.2	96.6	2.5	150
100	10.6	31.7	18.8	38.7	32.2	0.80	50

proportion

Dept. Sun Factory	Technical reference A036	Created by Marco Bernardo 10/06/2024	Approved by
		Document type Construction & Assembly	Document status Production
		Title Star Dome Dimensions Etape 1	DWG No. A036-STA-20244181
		Rev. A.0	Date of issue 17/06/2024
		Sheet 3/8	

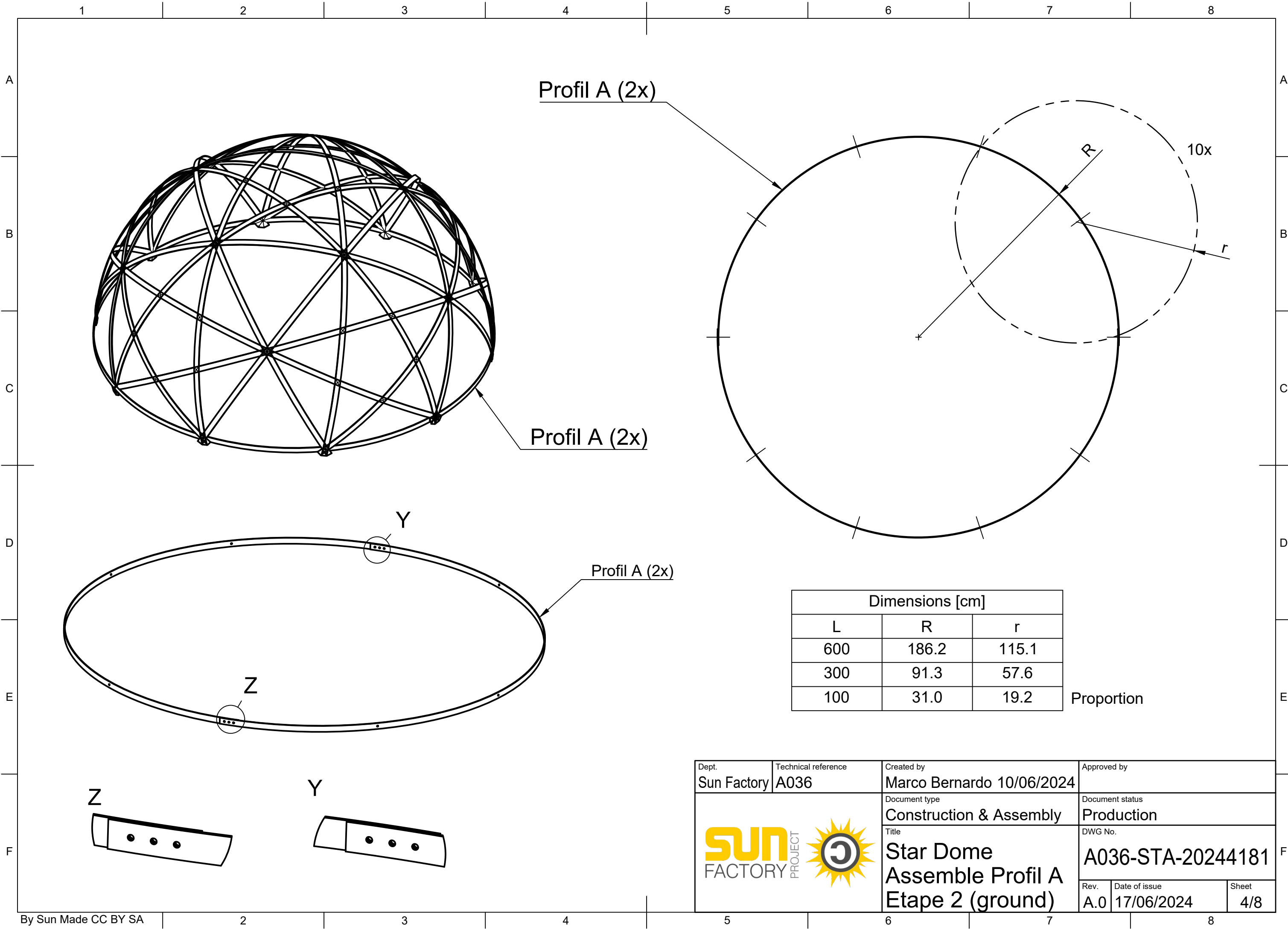

Profil A (2x)

Profil A (2x)

Profil A (2x)

Dimensions [cm]		
L	R	r
600	186.2	115.1
300	91.3	57.6
100	31.0	19.2

Proportion

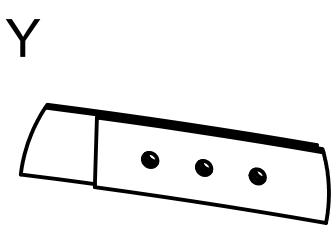
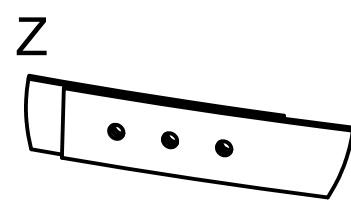

Dept. Sun Factory	Technical reference A036	Created by Marco Bernardo 10/06/2024	Approved by
		Document type Construction & Assembly	Document status Production
		Title Star Dome Assemble Profil A Etape 2 (ground)	DWG No. A036-STA-20244181
	Rev. A.0	Date of issue 17/06/2024	Sheet 4/8

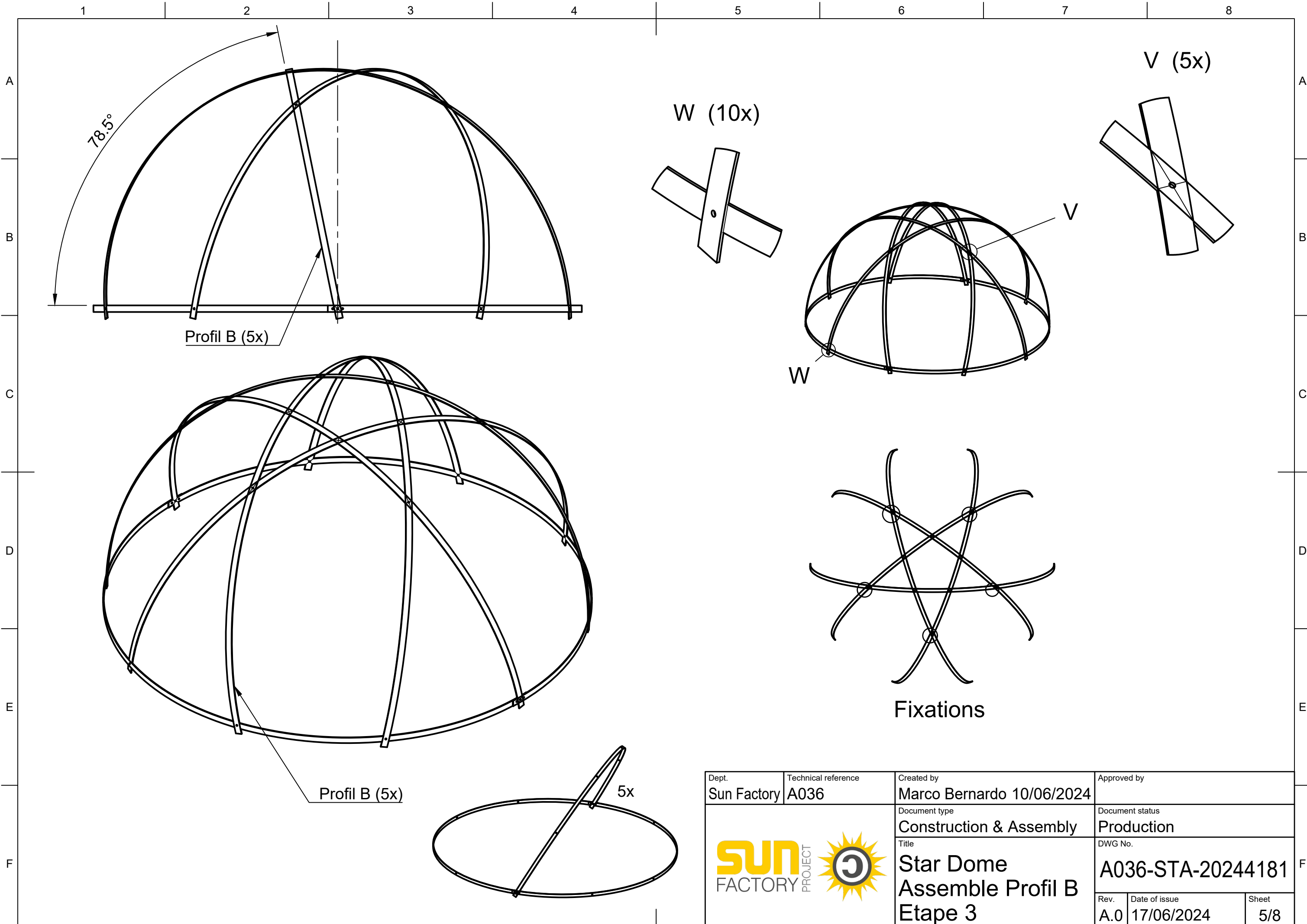

Dept. Sun Factory	Technical reference A036	Created by Marco Bernardo 10/06/2024	Approved by
		Document type Construction & Assembly	Document status Production
		Title Star Dome Assemble Profil B Etape 3	
		DWG No. A036-STA-20244181	
Rev. A.0	Date of issue 17/06/2024	Sheet 5/8	

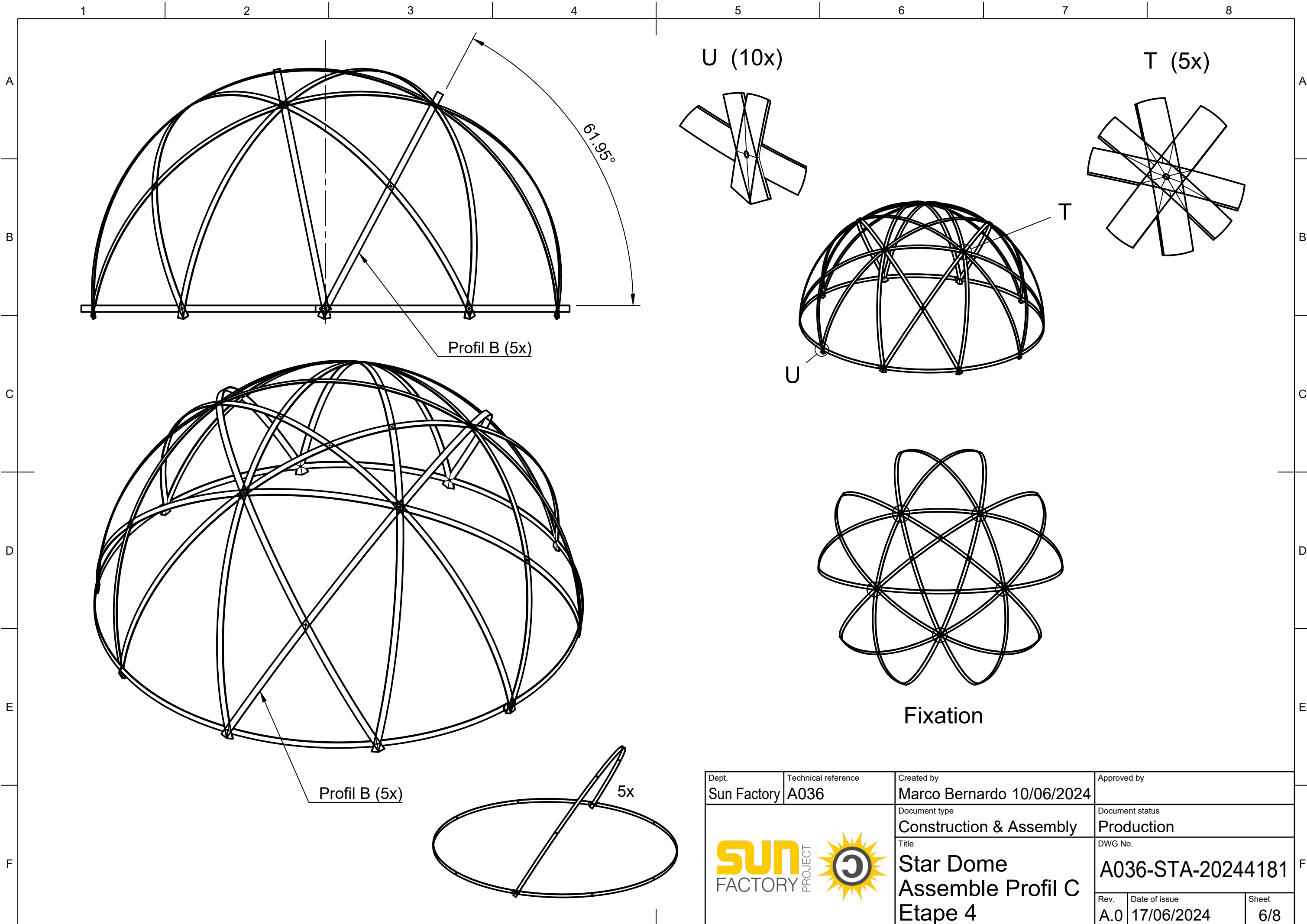

Dept. Sun Factory	Technical reference A036	Created by Marco Bernardo 10/06/2024	Approved by
		Document type Construction & Assembly	Document status Production
		Title Star Dome Assemble Profil C Etape 4	
		DWG No. A036-STA-20244181	
Rev. A.0	Date of issue 17/06/2024	Sheet 6/8	

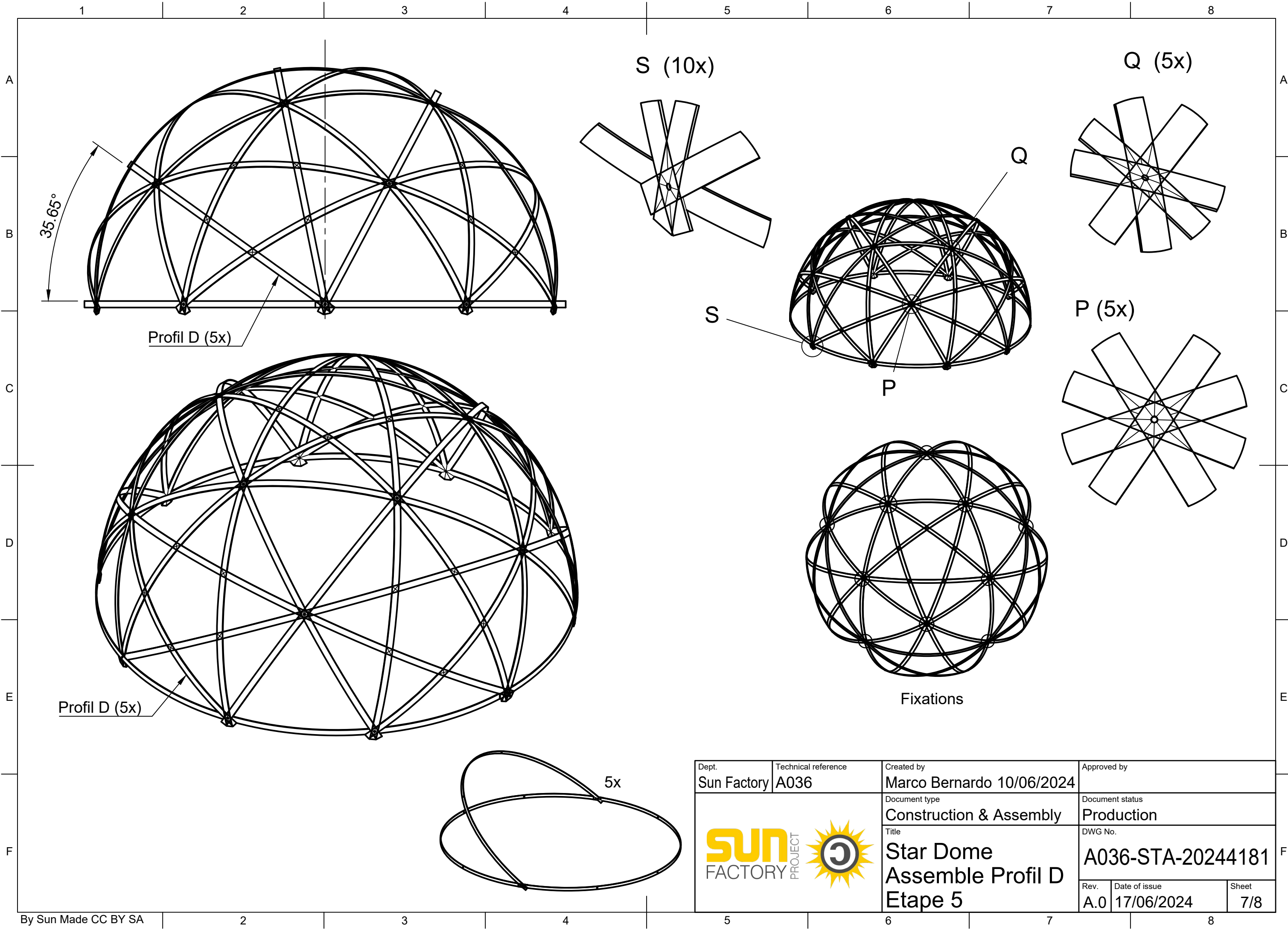

Dept. Sun Factory	Technical reference A036	Created by Marco Bernardo 10/06/2024	Approved by
		Document type Construction & Assembly	Document status Production
		Title Star Dome Assemble Profil D Etape 5	
		DWG No. A036-STA-20244181	
Rev. A.0	Date of issue 17/06/2024	Sheet 7/8	

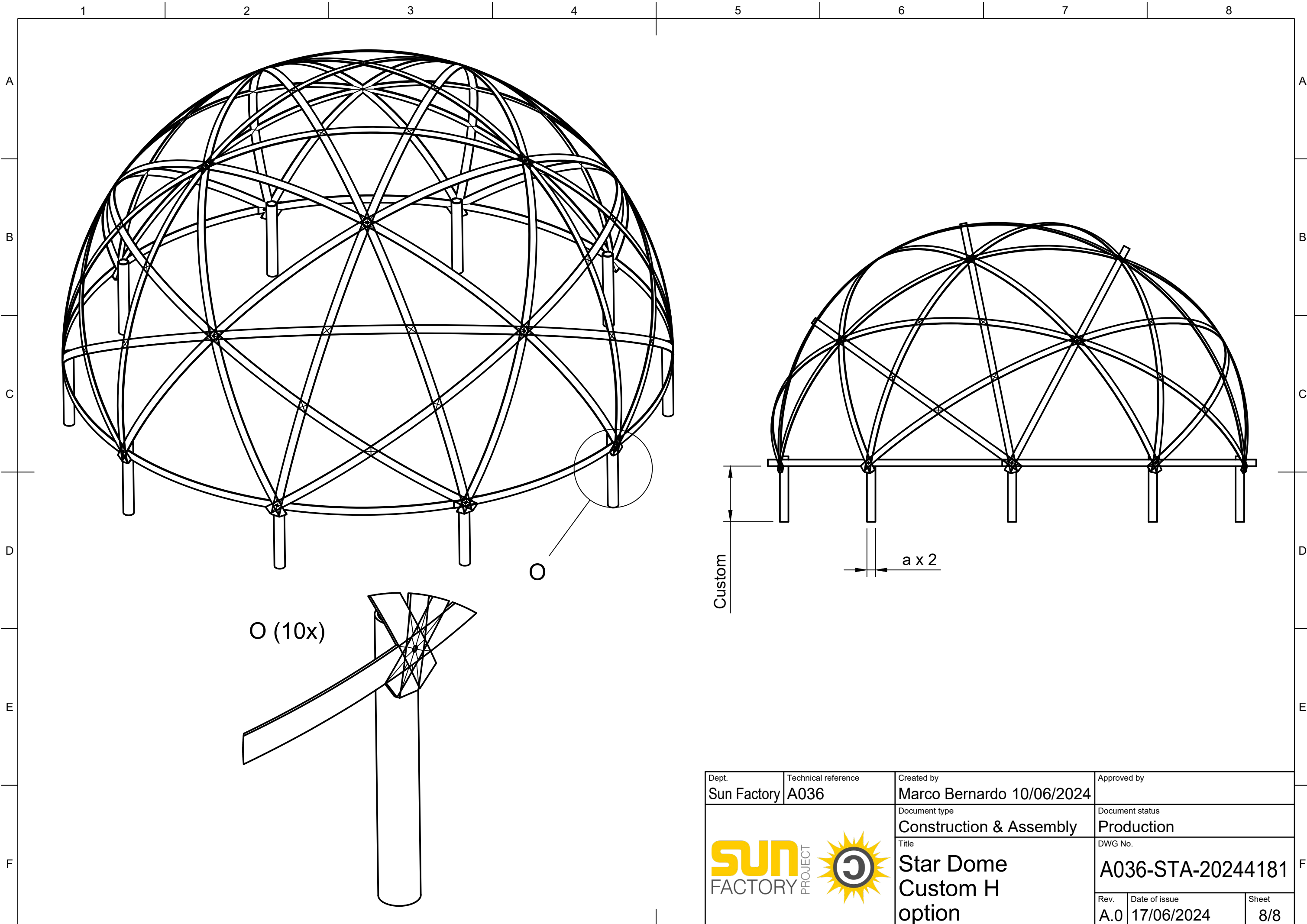

Dept. Sun Factory	Technical reference A036	Created by Marco Bernardo 10/06/2024	Approved by
		Document type Construction & Assembly	Document status Production
		Title Star Dome Custom H option	DWG No. A036-STA-20244181
Rev. A.0	Date of issue 17/06/2024	Sheet 8/8	